

# PMX

## POWER ASCENDER

### User manual

Introduction	A
Product safety & system description	B
Rope	C
General safety guidelines and lifting systems	D
Starting/operating the Engine	E
How to use the Ascender	F
Service & maintenance	G
Warranty terms	H
Technical data	I





**HAND-BUILT  
IN SWEDEN**

## DISCLAIMER

### WARNING

**Training and experience are required to lower the risk of serious bodily injury or death.**

This user's manual provides general information about safe operation and risks associated with the use of the ActSafe PMX Power Ascender. It also gives details of maintenance procedures.

Never use the equipment unless you have read and understood this manual and completed ActSafe approved training in the use of the Power Ascender System. ActSafe Systems AB, our partners and subsidiaries, disclaim any liability for damages, injuries or death resulting from the use of the equipment which is not in compliance with this manual.

This manual may be updated without notice.

For more information about updates and safety warnings, visit [www.actsafe.se](http://www.actsafe.se)



**Failure to read and follow the instructions within this manual may result in fire, damage to property, personal injury or death.**

## FOREWORD

Thank you for choosing the ActSafe PMX Ascender from ActSafe Systems.

This Ascender has been designed as an ultra-portable and versatile lifting tool for lifting people or equipment in a safe and effective way. It revolutionises working in a vertical environment.

# A

## INTRODUCTION

About ActSafe	<b>A.01</b>
About this manual	<b>A.02</b>
Definitions	<b>A.03</b>

# A

**We are completely committed to our customers and do our utmost to deliver top quality products and service.**



**ISO 9001**

**BUREAU VERITAS**  
Certification



## **A.01** ABOUT ACTSAFE

ActSafe is a pioneer in developing powered rope ascenders and has been delivering high-performance equipment since 1997.

ActSafe has a worldwide distribution network of dedicated experts selling our innovative products to a wide variety of users. Our Power Ascenders have been successfully used for installing fireworks at the top of the Eiffel Tower, hostage rescue from pirates at sea and providing essential logistical support in offshore wind turbines.

ActSafe products are redefining the possibilities for work in vertical environments.

## A.02 ABOUT THIS MANUAL

This manual gives detailed information on features and safety. However, this manual cannot replace the need for training and experience. The Ascender must only be used by operators who have undergone the ActSafe-approved training.

Safety messages of extra importance are highlighted throughout this manual using the signals 'danger', 'caution', 'note' and 'recommendation':



### **DANGER**

Not following instructions or training methods may result in **SERIOUS BODILY INJURY** or **DEATH**.



### **CAUTION**

Not following instructions or training methods may result in **BODILY INJURY**, or **DAMAGE TO PROPERTY**.



### **Note**

Important information on the use of the equipment used with the Ascender.



### **RECOMMENDATION**

Instructions and tips on how best to use the Ascender.

## A.03 DEFINITIONS

### **Active/loaded rope**

Loaded end of the work-positioning rope system.

### **Anchor**

Attachment point for rope or Ascender.

### **Ascending**

Moving up the rope.

### **Backup system**

A rope system which captures the load in case of primary rope failure. Approved according to backup system requirements.

### **Competent Person**

Operator with adequate training, experience and certification.

### **Descending**

Moving down the rope.

### **Passive/dead rope**

Unloaded end of the work-positioning rope system.

### **Primary rope**

Work rope system used with Ascender. Rope must be 11 mm and approved according to *EN1891 A* or an ActSafe Equipment Lifting Rope depending on the application.

### **User/operator**

Operator of the Ascender.

### **Secondary rope**

See 'Backup system'.

### **SWL**

Safe Working Load. The maximum load (as certified by a competent person) that an item of lifting equipment may raise, lower or suspend under particular service conditions.

### **WLL**

Working Load Limit. The maximum load that an item of lifting equipment is designed to raise, lower or suspend.



# B

## PRODUCT SAFETY & SYSTEM DESCRIPTION

Product safety	<b>B.01</b>
Usage exclusions	<b>B.02</b>
System description	<b>B.03</b>
Rope mechanism	<b>B.04</b>

# B

## B.01 PRODUCT SAFETY



ActSafe Ascender operators must, before first use, have undergone training in the safe use of the Ascender by either ActSafe Systems AB or by an ActSafe-approved training partner or ActSafe distributor.

The ActSafe Ascender must be checked before every use by a Competent Person and must undergo a minimum of one inspection per year by ActSafe Systems AB or an ActSafe-authorized person. More frequent inspections may be required by your national regulations.

## B.02 THE ASCENDER **MUST NOT BE USED:**



- » For any purpose other than that for which it has been designed
- » Indoors in an unventilated area (exhaust gases contain carbon-monoxide, an odourless deadly toxin)
- » In an explosive environment
- » If modified in any way by anyone other than ActSafe Systems
- » After a free fall from a height of more than 0.5 m or against any hard surface
- » If you are tired, ill, using prescription medication that prevents you from using machinery, or under the influence of alcohol and/or drugs
- » Without having performed a pre-use check
- » If subjected to misuse in any way so that parts or components could have been damaged
- » The Ascender system should not be exposed to high impact forces caused by people or loads falling into the system
- » If the operator is unsure of how to use the Ascender safely

# B

## B.03 SYSTEM DESCRIPTION

### CAUTION

**DO NOT** use the carrying handle or the engine protection frame as rigging points, this part is only designed to lift the weight of the PMX Ascender!

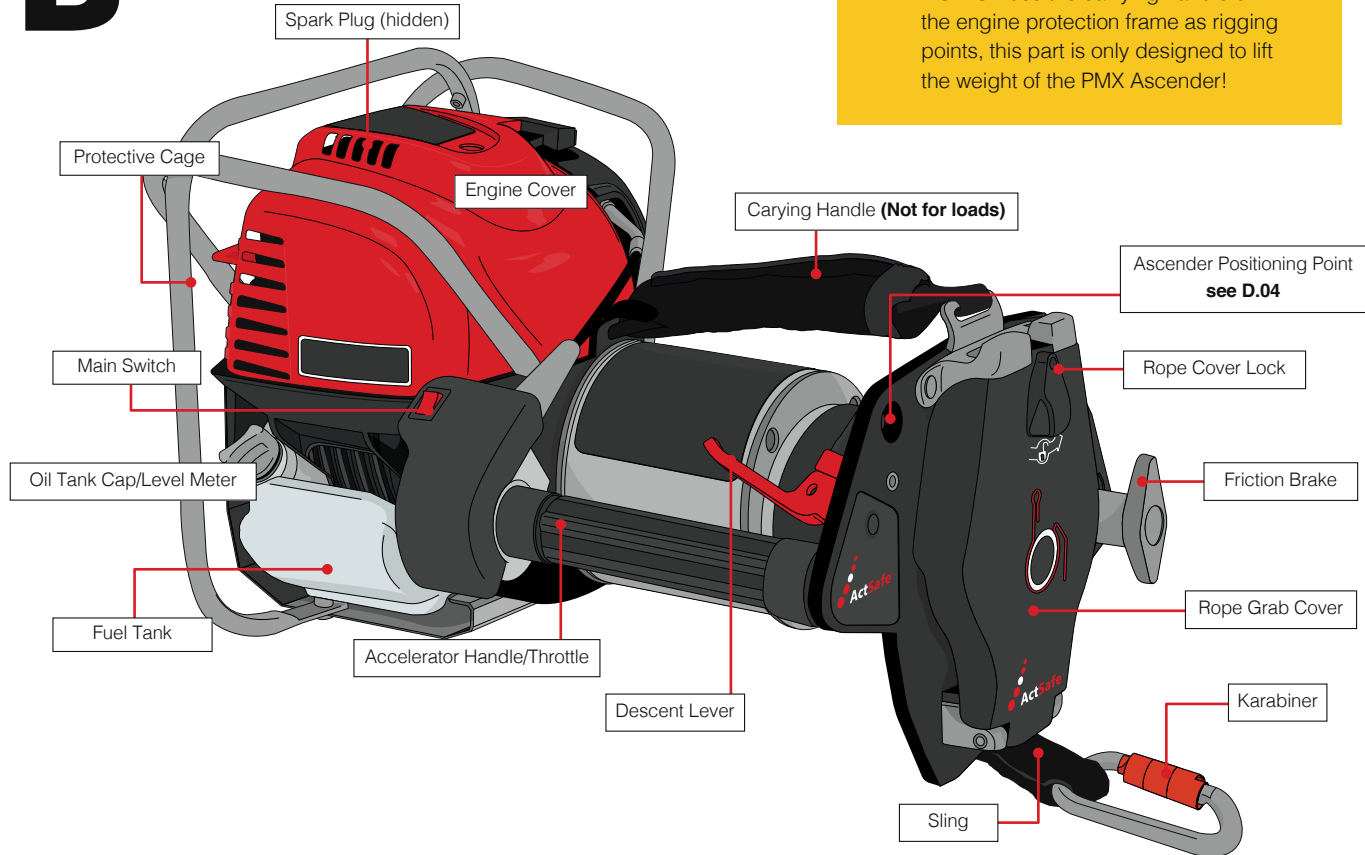

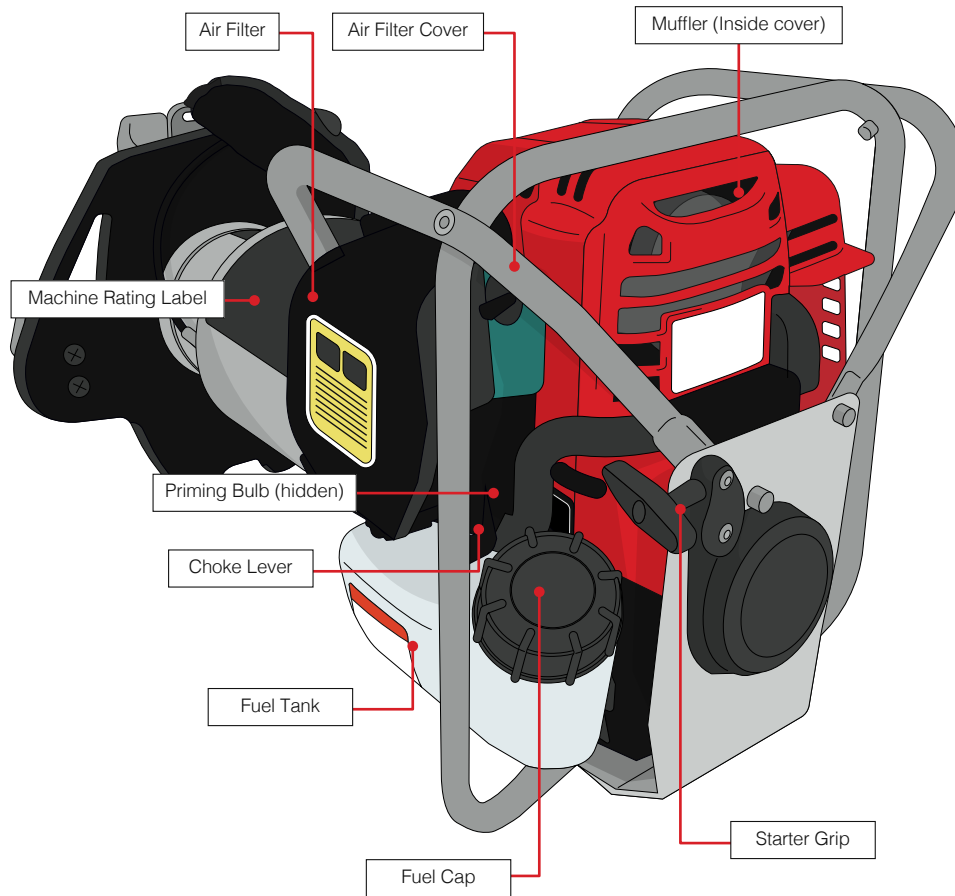

### Machine Rating label

The Ascender is supplied with a machine rating label attached to the housing. This label must not be removed!

The PMX Ascender is approved under the Machinery Directive 2006/42/EC for lifting both people and equipment with a Working Load (WLL/SWL) of 250 kg (551 lb).

### B.04 ROPE MECHANISM

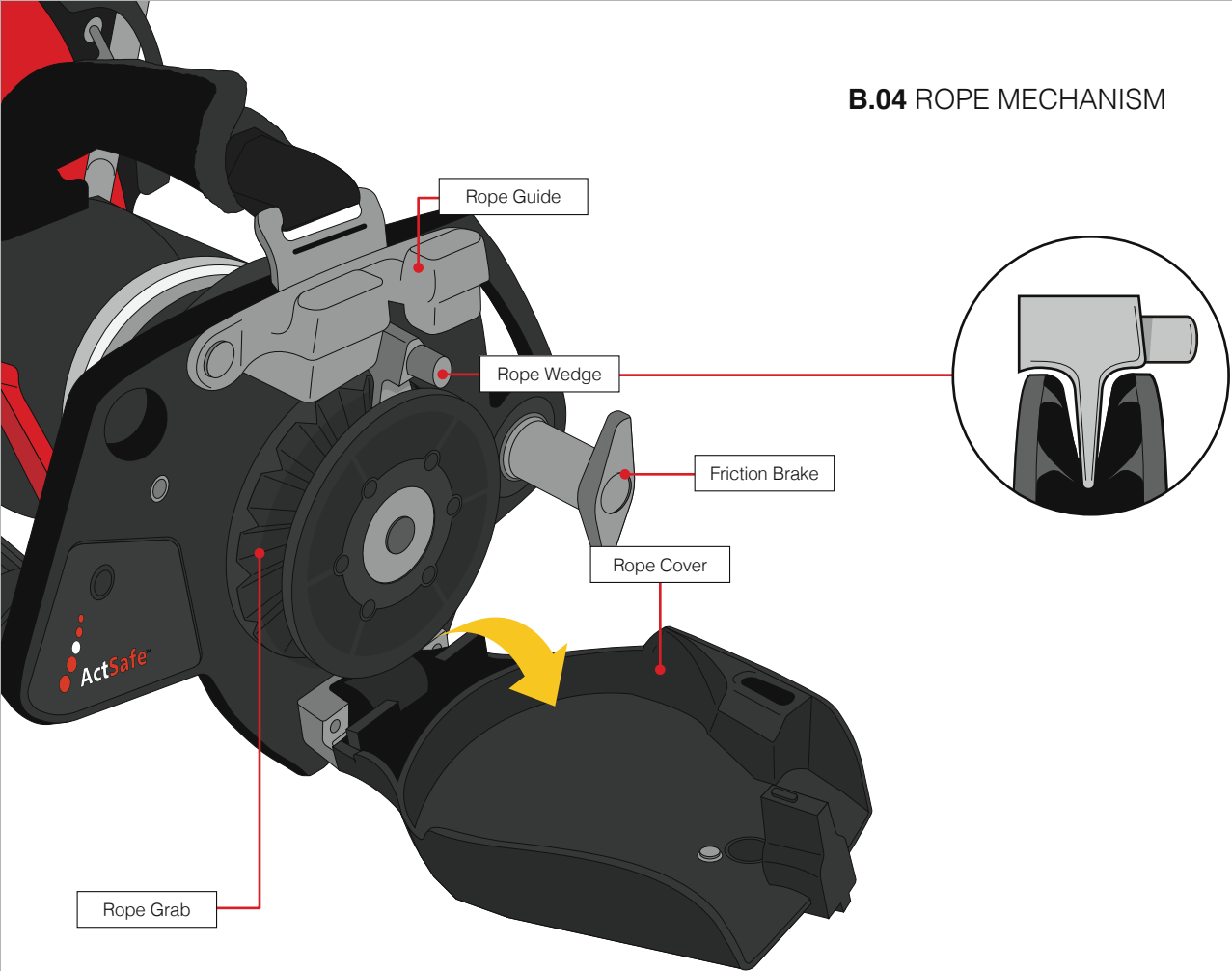

# C

## ROPE

Rope type  
and preparation

---

**C.01**

# C

## C.01 ROPE TYPE AND PREPARATION

**The correct choice of rope type depends on whether the Ascender is being used to lift or lower equipment or personnel.**

**Check with your ActSafe supplier or at the ActSafe website for the latest list of suitable ropes.**

### **Rope recommendations**

Rope recommendations for the PMX Ascender depend on the type of application, whether personnel or equipment lifting.

### **Equipment lifting**

The ActSafe Equipment Lifting Rope (ELR) is the only approved rope to be used in the equipment lifting system and can be ordered at ActSafe or via your ActSafe distributor.

### **Personnel lifting**

All ropes that are used for personnel lifting must meet EN 1891 A with a diameter of 11 mm (7/16") and should be of a solid construction. It is recommended to use ropes in ActSafe Ascenders that have passed our rope suitability test. A list of suitable ropes

and the rope testing procedure, in case you want to perform your own suitability tests, can be found at our website or contact your ActSafe distributor for more information. The reason for having this rope list is that especially softer ropes are unsuitable for the use in ActSafe Ascenders. Softer ropes should be avoided because they deform under load, grip is poor and can potentially jam the Rope Grab system.

### **Pre-Soaking**

It is recommended that only pre-soaked ropes are used with ActSafe Ascenders. New ropes should be put in cold water <40°C (<104°F) for 24 hours and dried slowly afterwards.



**This will make ropes more suitable for use in ActSafe Ascenders for two reasons:**

### **1. Rope density**

Pre-soaking makes ropes denser. The fibres will absorb the water and will shrink when drying. The result is that all fibres become more densely aligned and the sheath sits tighter around the core of the rope. This will make the rope more solid and will consequently result in less mantle slippage and deformation and thereby lead to better grip in the Ascender.

### **2. Oil dissolution**

During the production process some oil is added to the rope fibres in order to reduce the friction between the individual fibres. When soaking the rope in cold water some surface oil in the sheath of the rope

will dissolve. This will contribute further to a better grip. Do not soak ropes in warm water, this will lead to greater dissolution of oil, which will have a negative impact on the rope properties.



### **CAUTION**

Always make sure that the rope is in good condition.



### **RECOMMENDATION**

A new rope will get an increased service life if it is soaked in cold water before the first use.

Avoid getting sand or dirt onto/ into the ropes since it will wear the Rope Grab and Rope Guide. Use a Rope Mat, Rope Bag or similar.





# D

## GENERAL SAFETY GUIDELINES AND LIFTING SYSTEMS

General safety guidelines	<b>D.01</b>
Personnel lifting	<b>D.02</b>
Personnel safety checklist	<b>D.03</b>
Personnel lifting setup	<b>D.04</b>
Equipment, materials and tool lifting	<b>D.05</b>
Basic lifting safety rules	<b>D.06</b>
Equipment lifting setup	<b>D.07</b>
ActSafe Training Network	<b>D.08</b>

# D

## D.01 GENERAL SAFETY GUIDELINES

**The PMX Ascender is designed for both personnel and equipment lifting. These applications have different system requirements that are described in the following pages.**

### **DANGER**

DO NOT USE the Ascender if you are tired, ill, using prescription medication that prevents you from using machinery, or under the influence of alcohol and or drugs.

- » Operate the Ascender according to the advice contained within this user manual and pre-planned work instructions (lift plan, access plan)
- » Only trained and competent operators should operate the PMX Ascender and its ancillary equipment
- » Plan and evaluate your work carefully. A rescue plan should be in place
- » Plan for appropriate supervision of work
- » Perform a toolbox talk/safety briefing before starting the work
- » Use only approved and inspected equipment. This goes for the Ascender, PPE and/or lifting equipment
- » Inspection of equipment must be carried out in accordance with local regulations. The Ascender should undergo a documented inspection at least once every year
- » Pre-use check of the Ascender should be carried out in accordance with the inspection guidance provided ( see F.11)
- » Use PPE (Personnel Protective Equipment) such as helmet, gloves and protective eye wear when required
- » Keep your hands, hair and clothing away from moving parts
- » Keep a constant eye on the Rope Guide to ensure that the rope is running smoothly through the rope mechanism

### **CAUTION**

Do not hold the loaded rope when ascending as there is a risk of pinching.

## D.02 PERSONNEL LIFTING

**The PMX Ascender, when used to lift people, must be used with personnel protective equipment approved for work at height, rope access and/or rope rescue.**

### Basic requirements:

The rope system must consist of a primary work rope system and a secondary backup rope system.

For personnel lifting the primary rope used in the Ascender must be approved to *EN1891 A* and have a diameter of 11 mm and the backup system must fulfill the respective requirements.

Each rope system must be connected to an appropriate anchor that meets requirements for personal lifting anchors. A competent person shall judge if the anchor points are sufficient and safe to use.



### DANGER

DO NOT USE the Ascender without a backup system. Take particular care of the suitability of the system when lifting more than one person.

## D.03 PERSONNEL SAFETY CHECKLIST

### Before use make sure that you:

- ✓ Check all equipment and components
- ✓ Wear appropriate clothing and tie back any loose clothing or hair
- ✓ Do not swing excessively while descending/ascending
- ✓ Only use the Ascender if you have successfully completed approved ActSafe training
- ✓ Have an emergency plan in place



### Note

The supplied ActSafe karabiner may be replaced with any other *EN362* connector. All other parts of the Ascender should only be replaced with original ActSafe parts by an ActSafe-approved service engineer.

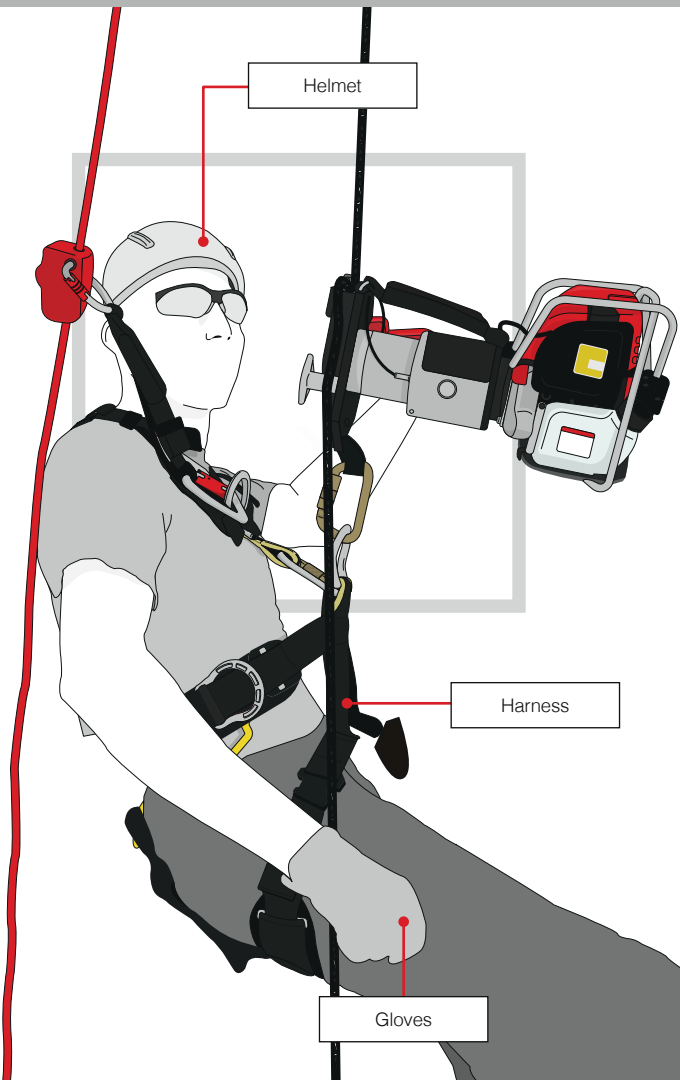

## 2-Rope system

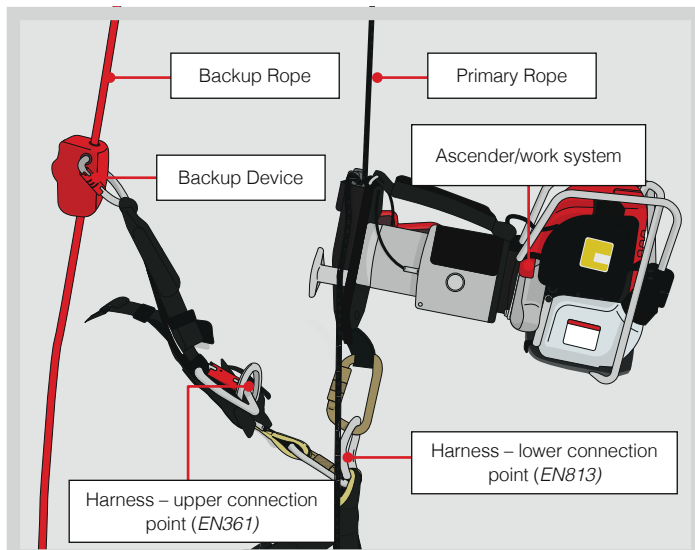

### **i** RECOMMENDATION

A work seat is recommended for comfort and safety.

### **✓** Note

When driving the Ascender the operator must wear a fall arrest harness that is also suitable for work-positioning/rope access.

## D.04 PERSONNEL LIFTING SETUP

Displayed here are the four standard personnel lifting setups that are suitable for use with the PMX Ascender. They are shown for illustration purposes only. For further guidance, please contact your local ActSafe supplier or ActSafe directly.



### CAUTION

Always hold the unloaded rope when the Ascender is rigged to an anchor.

### Active / Running Basic setup

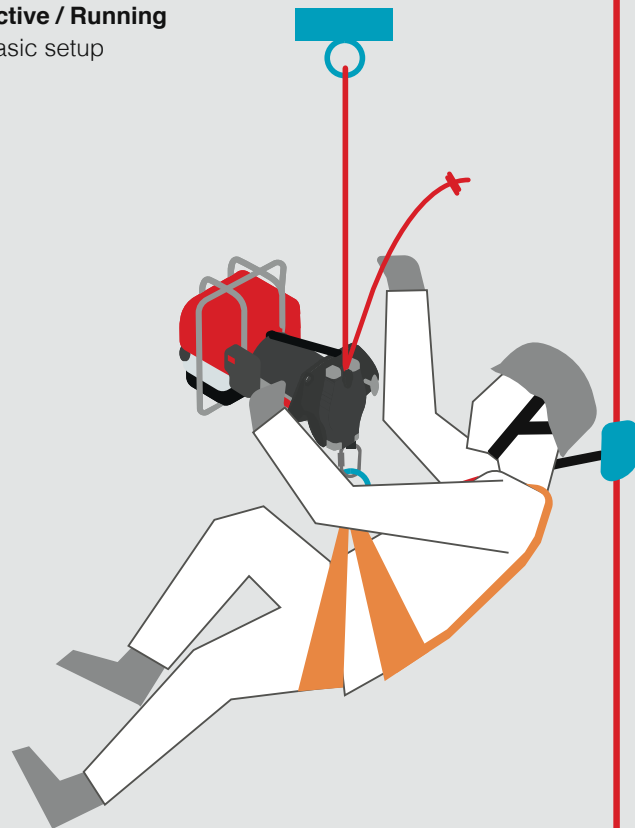

**Top Rigged**  
Basic setup

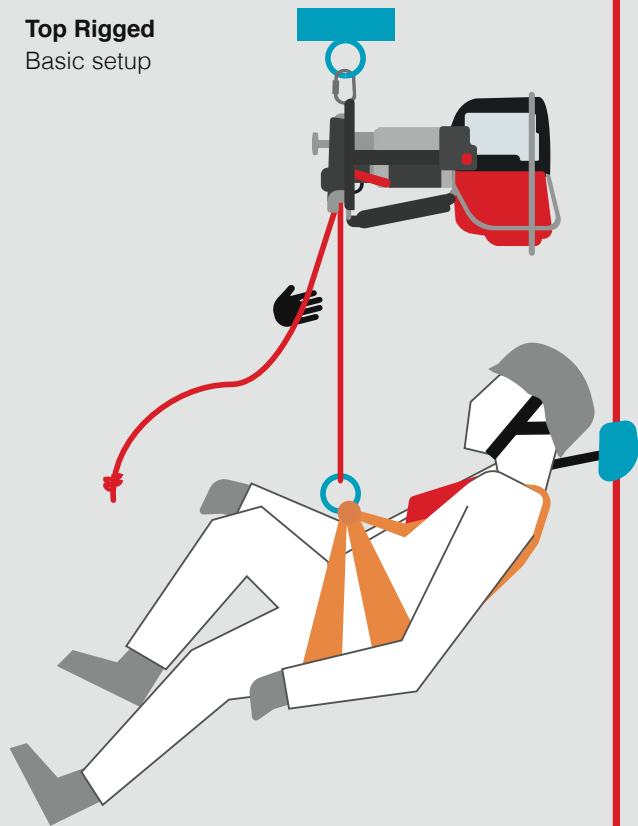

**Bottom Rigged**  
Basic Setup

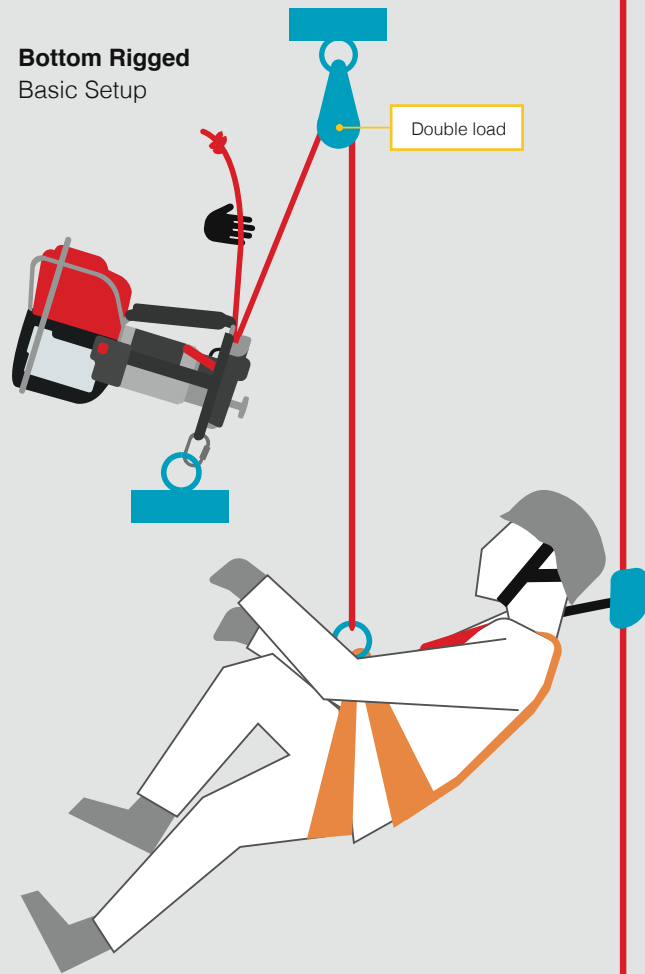



**Pulley**

Expert use only

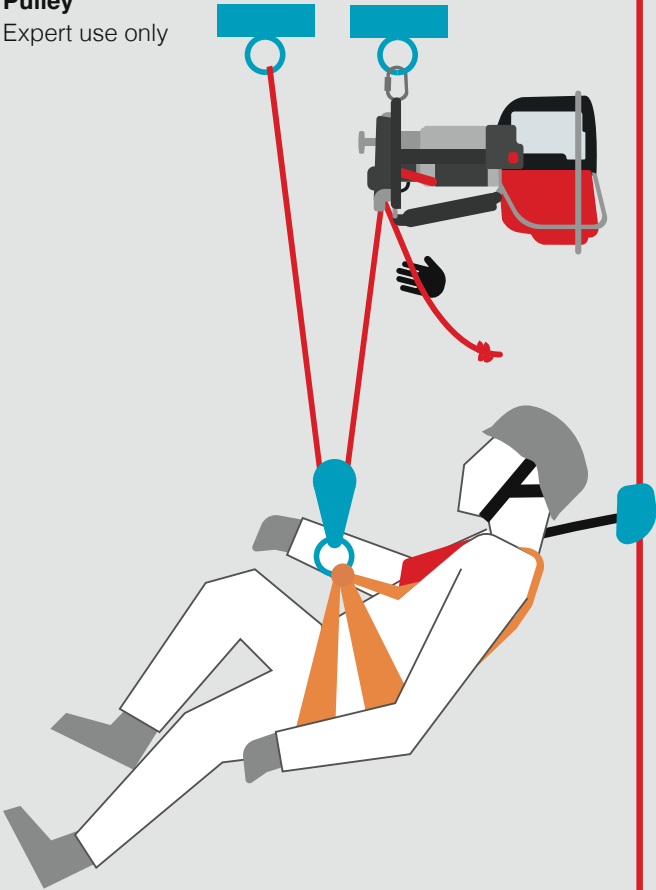

**Pulley**

Expert use only.  
PMX pulley rigging  
on a single anchor

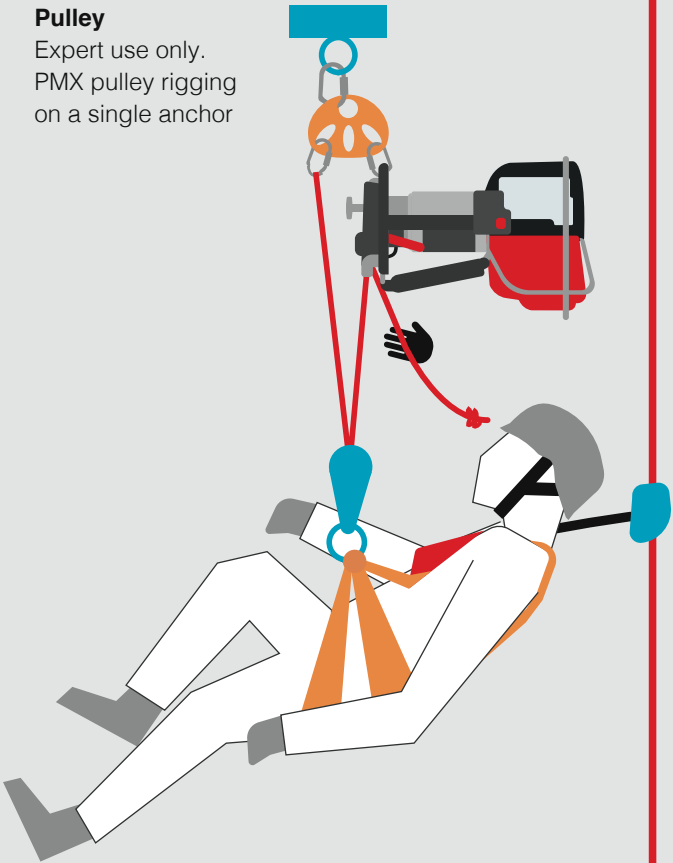

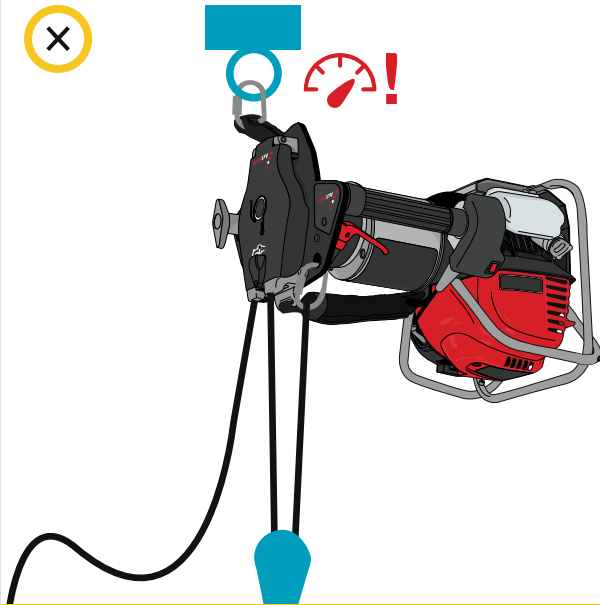

## CAUTION

Do not use the Ascender Positioning Point as an anchor extension for making pulley systems as this would risk double-loading the frame plate, Sling Bolt and Connection Sling with the risk of having an insufficient factor of safety on the Connection Sling.

## Ascender Positioning Point

Correct use

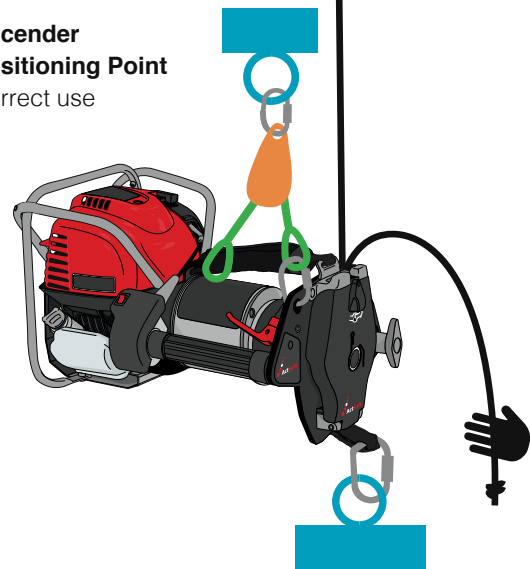

## Note

This setup can be used in cases where the Ascender is rigged to an anchor and the operator wishes to avoid the Ascender dropping when the rope becomes unloaded. However, the Ascender must be allowed to rotate freely while suspended.



## D.05 EQUIPMENT, MATERIAL AND TOOL LIFTING

The PMX Ascender is, in combination with the ActSafe Equipment Lifting Rope (ELR), approved under the Machinery Directive as an equipment lifting system provided that all other equipment used also meets lifting requirements. The lifting system must be connected to an appropriate anchor that meets requirements for load lifting anchors (a competent person shall judge if the anchor is sufficient and safe to use).

### **i** RECOMMENDATION

Lifting operations are ideally performed with a three person team. A lifting supervisor, a slinger for attaching loads and an Ascender Operator.

### **✓** Note

The supplied ActSafe karabiner may be replaced with any *EN13889* shackle with a minimum WLL of 0.5 t. All other parts of the Ascender should only be replaced with original ActSafe parts by an ActSafe-approved service engineer.



## D.06 BASIC LIFTING SAFETY RULES



Always keep an eye on the load while lifting



Avoid excessive inching (i.e. short pulses of the motor)



Do not exceed the Safe Working Load (SWL) of the entire lifting system



Stay clear of the load whilst lifting



Do not try to lift fixed or obstructed loads



Do not stand under the suspended load



Do not side-pull loads



Use hand signal or radio communications during lifting operation

## D.07 EQUIPMENT LIFTING SETUP

Displayed here are the four standard lifting setups that are suitable for use with the PMX Ascender. They are shown for illustration purposes only. For further guidance, please contact ActSafe or an ActSafe distributor.

### ! CAUTION

DO NOT let the rope become obstructed or blocked when being guided into the Ascender

### ✓ Note

The Ascender operator should, at all times, control the unloaded rope during lifting operations to avoid the rope twisting when going into the Ascender.

**Top-rigged**  
Basic setup

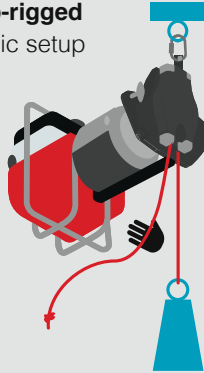

**Bottom-rigged**  
Basic setup

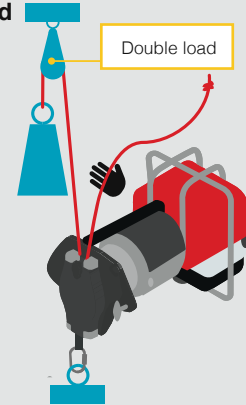

**Running Ascender**  
Expert use only

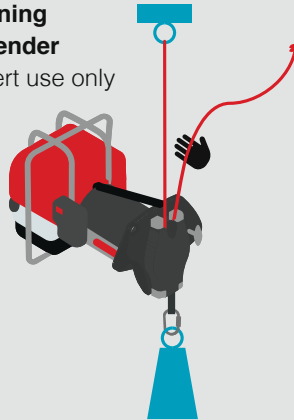

**Pulley**  
Expert use only

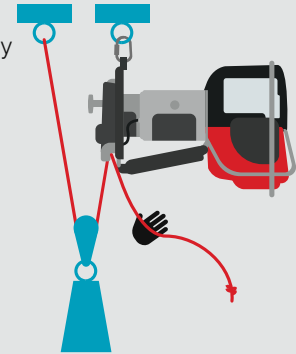

## D.08 ACTSAFE TRAINING NETWORK

The ActSafe Power Ascenders are extremely versatile high-tech lifting tools that are designed for use in demanding environments.

Working with these Ascenders requires experience, competence and a thorough understanding of their possibilities and limitations. Therefore, training is essential.

We offer the ActSafe training programme through our network of highly competent instructors, who are specialists in their respective field of operation and will help you get the most out of your ActSafe Ascender.

ActSafe training is available for different skill levels and fields of application and can be provided on site or in training centres all around the world. Get in touch with your local distributor or with ActSafe to learn more about training possibilities.



## Operator lifting

ActSafe training is developed to offer a modular system with the aim to meet the level and needs of the customer. At the end of each training course the operator will be able to use the Ascender System in a safe and appropriate manner. For bespoke training solutions contact ActSafe.

### PERSONAL LIFTING ACTSAFE BASIC

**Experience:** Hold a valid work at height certificate.

**Duration:** Minimum 2 DAY

This is a modular bespoke training for future Ascender operators to give them the knowledge and skills for using Ascenders for designated task.

The training outline and duration will vary upon the skill level of the participants.

### PERSONAL LIFTING ACTSAFE ADVANCED

**Experience:** Rope access and rope rescue professionals.

**Duration:** Minimum 1 DAY

This training is designed to give rope professionals a thorough understanding of the possibilities of integrating Ascenders in their rope systems.

## Equipment lifting

### ACTSAFE EQUIPMENT LIFTING

**Experience:** Delegate should have completed training for working at height and must meet statutory training requirements for the lifting of loads.

**Duration:** 4 HOURS

This training is intended for specialist workers who will use the Ascender as their everyday equipment-lifting tool.



# E

## STARTING/OPERATING THE ENGINE

Engine safety	<b>E.01</b>
Fuel safety	<b>E.02</b>
Starting the engine	<b>E.03</b>

## E.01 ENGINE SAFETY



### **DO NOT START THE ENGINE:**

- » If the Air Filter or its cover has been removed

### **DO NOT RUN THE ENGINE:**

- » Indoors in an unventilated area (exhaust gases contain carbon monoxide, an odourless deadly toxin)
- » Without Silencer. Check the Silencer on a regular basis and replace if necessary

- » If there is an accumulation of grass, leaves or other flammable material under, on or behind the Silencer
- » **DO NOT** use a removed spark plug to determine whether it is sparking
- » Touch the Silencer, Cylinder or Radiator when they are hot – danger of burn



### **CAUTION**

Make sure that hot engine parts **DO NOT** come into contact with skin, clothes, rope or anything that would be damaged by excessive heat.

## E.02 FUEL SAFETY



### DO NOT:

- » Run the Engine if petrol has been spilled or it smells of petrol or if there is any other danger of explosion
- » Refuel the Ascender in non-ventilated areas such as inside a building
- » Store, spill or handle petrol near any ignition source, such as unshielded flames, sparks or very hot parts
- » Open the Fuel Tank or fill the Fuel Tank when the Engine is still hot or running. (the Engine should cool for a least 2 minutes before refuelling)
- » Transport the Engine if there is fuel in the tank

### REFUELLING

Follow these instructions when refuelling to minimise risk of fire and personal injury:

- » Turn the Engine Switch off
- » Allow the Engine to cool
- » Open the Fuel Tank
- » Refill the fuel
- » Close the Fuel Tank

Move Ascender at least 3 m (10 ft) away from the refuelling site before starting the Engine.



### Fuel

EU 95/US 91 Octane fuel is recommended for use in the engine. Aspen fuel may also be used. Do not mix these types of fuel since it can cause a clogged fuel filter.

## E.03 STARTING THE ENGINE



### Note

Before starting, ensure that the Engine is filled up with fuel and oil. See section G.01.

1. Place the Ascender on the ground.
2. Turn the Main Switch on.
3. Press the Priming Bulb several times until fuel can be seen (A, right).
4. Use the Choke if needed (cold engine) (B, right).
5. Pull the Starter Grip (C/D, over).

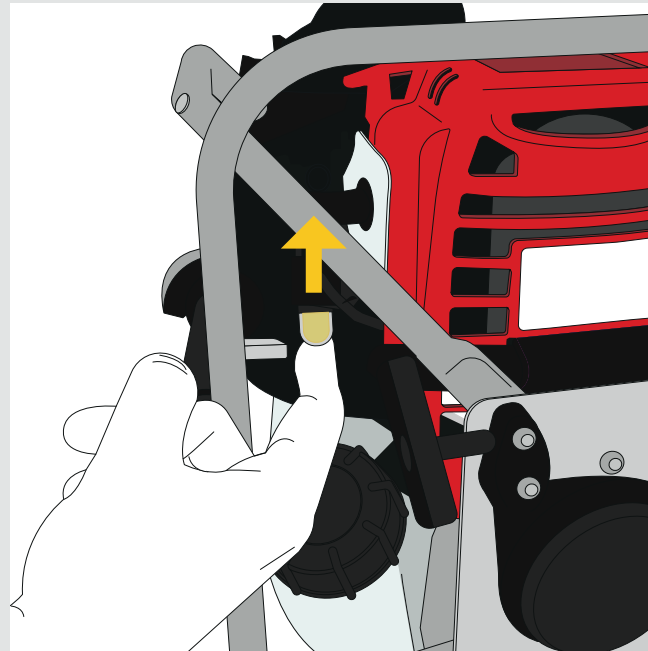

**A.** Pressing the Priming Bulb

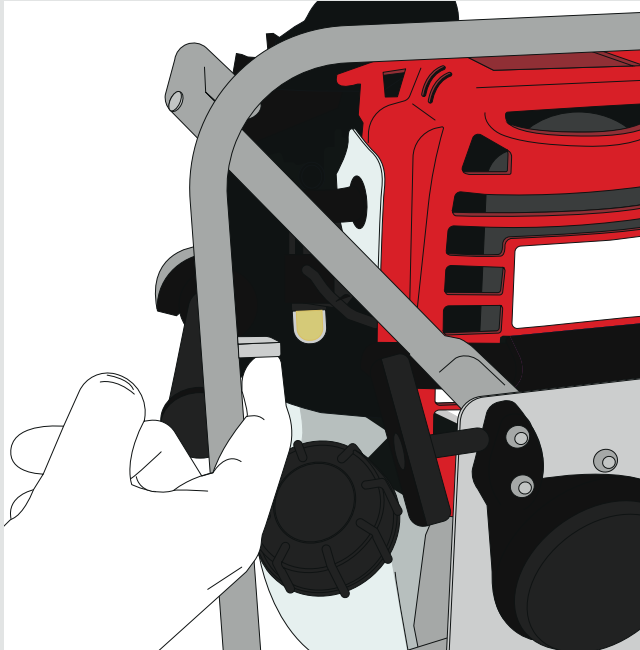

**B.** Activating the Choke

**i** **RECOMMENDATION**

Turn the Choke off as soon as the Engine runs.

Slowly pull the Starter Grip until you feel resistance. Then pull the Starter Grip strongly in order to avoid backstroke and injuries to hand or arm.

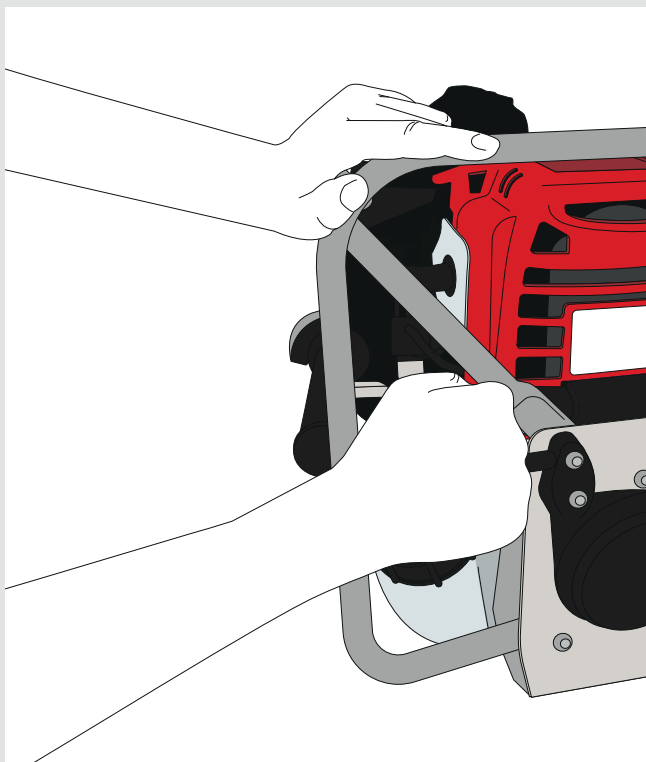

**C.** Hold the Starter Grip firmly

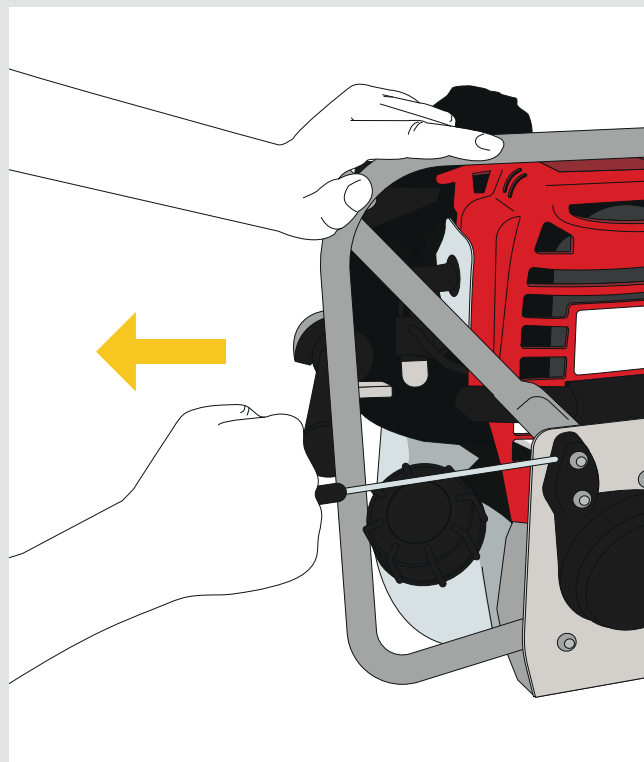

**D.** Pull the Starter Grip

# F

## HOW TO USE THE ASCENDER

Connecting the rope	<b>F.01</b>
Load limitation	<b>F.02</b>
Ascent	<b>F.03</b>
Descent	<b>F.04</b>
Controlled descending with heavy loads	<b>F.05</b>
Twisted rope and rotation	<b>F.06</b>
Checklist before and after use	<b>F.07</b>
Transportation	<b>F.08</b>
Storage	<b>F.09</b>

## F.01 CONNECTING THE ROPE

**The Ascender must be switched off while loading the rope.**

Ensure that the Ascender is switched off.



**1.** Open the Rope Cover by pulling on the Rope Cover and pushing the Rope Cover Lock to the right.

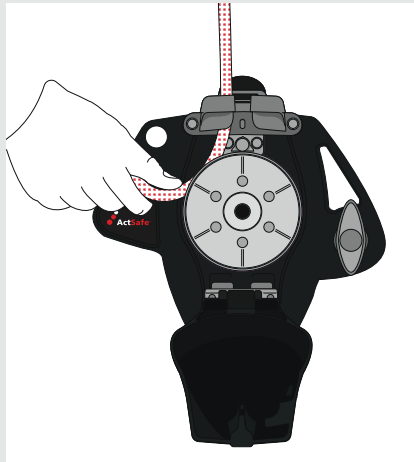

**2.** Feed the rope counter-clockwise through the slot in the Rope Guide and around the Rope Grab.

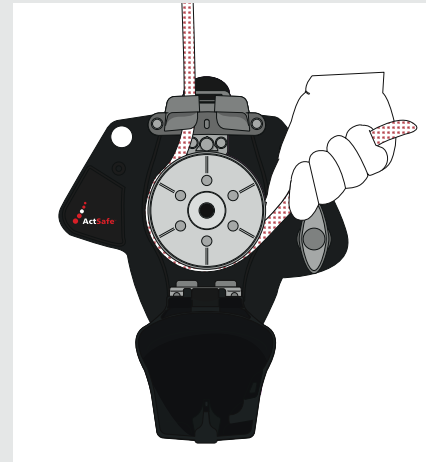

**3.** Continue feeding the rope in a counter-clockwise direction.



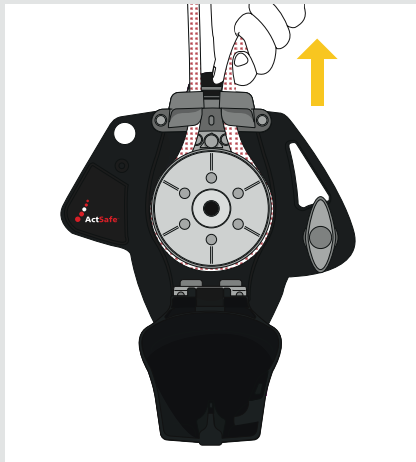

4. Feed the rope again through the slot in the Rope Guide.

Tighten the rope a little. The rope will be pulled into the Rope Grab and the Rope Cover can be closed more easily.

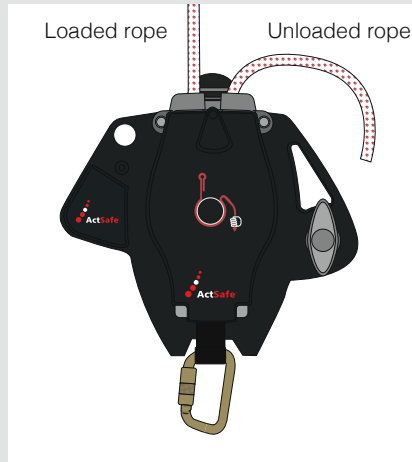

5. Close the Rope Cover and ensure it is locked. The Rope Cover lock should click into its position. A distinct 'click' should be heard. Never attempt to close the Rope Cover with force.

### **CAUTION**

Always check that the rope is attached correctly and has a stop-knot on the other end of the rope. Failure to attach the rope correctly could result in damage to the rope and loss of grip on the rope.

Ensure that the Rope Cover is locked into position.

## F.02 LOAD LIMITATION

The Ascender is equipped with load limitation that is based on a centrifugal friction function.

When the engine speed increases, two brake shoes are forced towards a drum; the friction causes the Rope Grab to be driven. If the Ascender is run according to the instructions, the clutch will withstand 250 kg (551 lb) before starting to slip.

The maximum load can also be limited if the Engine's power diminishes, e.g. if lower quality fuel is used, if the Air Filter is dirty, if the weather conditions are bad, if used at higher altitude (special high altitude carburetor jets are available).

When the Ascender is new, a somewhat lower lift capacity may be experienced due to the fact that the Clutch has not yet been run in.

If the Ascender still has a low lift capacity, despite a running in period, this can be due to worn-out clutch. Contact your ActSafe local distributor.

## F.03 ASCENT

1. Start the engine (see E.03)
2. Turn the Accelerator Handle towards you to increase the speed.
3. Position the Ascender so that the exhaust fumes will blow away from the user.
4. Feed away the 'dead rope' during the first few metres of ascent. After approximately 5 m (16 ft), the weight of the rope will be sufficient to 'clean' the Ascender from itself.
5. Stop the motion by turning the handle away from you or let it go, then slide the Ignition Switch to the STOP position.

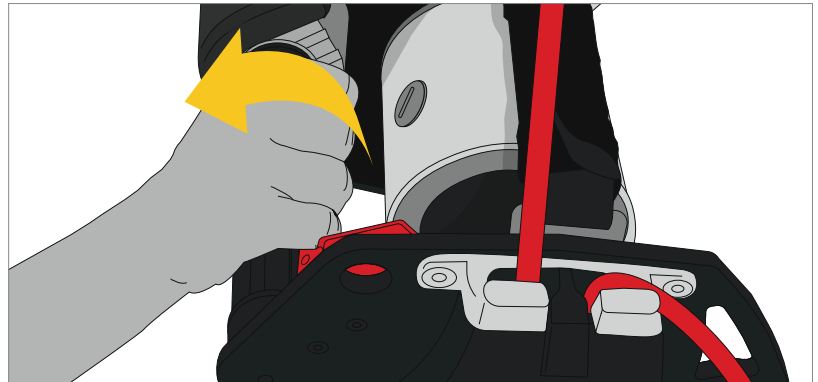

### **i** RECOMMENDATION

Hold on to the primary connection sling or karabiner with your right hand, if balance is needed.

Always keep the backup device in a high position.

Stand straight beneath the anchor point in order to avoid a pendulum movement when starting off the ground.

## F.04 DESCENT

Descending with the ActSafe PMX Ascender is very easy; the rope setup stays unchanged. The primary rope stays connected to the Ascender.

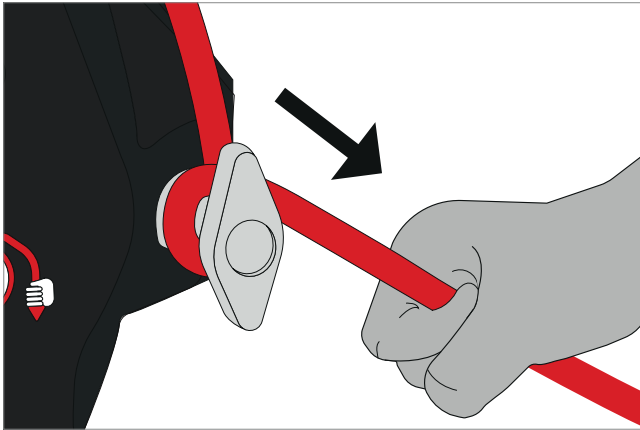

1. Take the primary rope and turn it at least once, in clockwise direction, around the Friction Brake of the Ascender.

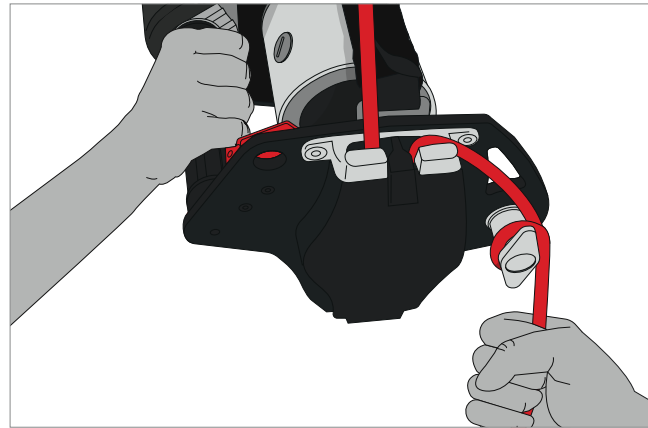

2. Firmly hold the primary rope below the Friction Brake. Place your left hand on the red braking lever just above the Throttle.

3. Pull in the Braking Lever and slowly feed some rope with your right hand and you will descend. The descending speed is controlled by the amount of rope which is fed through the right hand, braking hand; the descending lever always stays completely open. Make sure to keep the braking rope always in your hand and keep your hands away from the Friction Brake while descending!
4. If the braking is not sufficient because of new rope, etc. Stop descending, lock off the backup device, and put the rope a second time around the friction brake to increase the braking power. Start again descending as described at point 3. For descending with loads >150 kg (330 lb) see F.06

5. Stop descending by holding the rope more firmly and releasing the braking lever.

The descending speed is controlled by the braking hand.

ActSafe strongly recommends that the descending speed is NOT controlled by the braking lever; this will wear the engine brake down more quickly.



## CAUTION

Make sure to keep the Braking Rope always in your hand!

Keep your hands away from the Friction Brake. Ensure that hair, clothing or any loose items are not allowed to become caught.

A stopper knot should always be put at the end of both primary and secondary rope.



## RECOMMENDATION

Adjust the descending speed to the circumstances like: Terrain, load, weather and experience. Be aware and use common sense.

Turn the engine off during descending to avoid exposure to exhaust fumes and noise and also to save fuel.

## F.05 CONTROLLED DESCENT WITH HEAVY LOADS

### Descending with loads over 150 kg (330 lb):

1. Ensure that an appropriate backup device is used that is approved for 200 kg (440 lb) / 2 persons, alternatively two independent backup systems can be used.
2. Make an HMS with the outgoing rope on the Friction Brake as shown (right).
3. Ensure that there is no slack rope between the Rope Guide and the Friction Brake.
4. Hold the rope below the Friction Brake firmly and pull in the descending lever.
5. Always control your speed while descending and avoid sudden braking, this to prevent high dynamic loading.

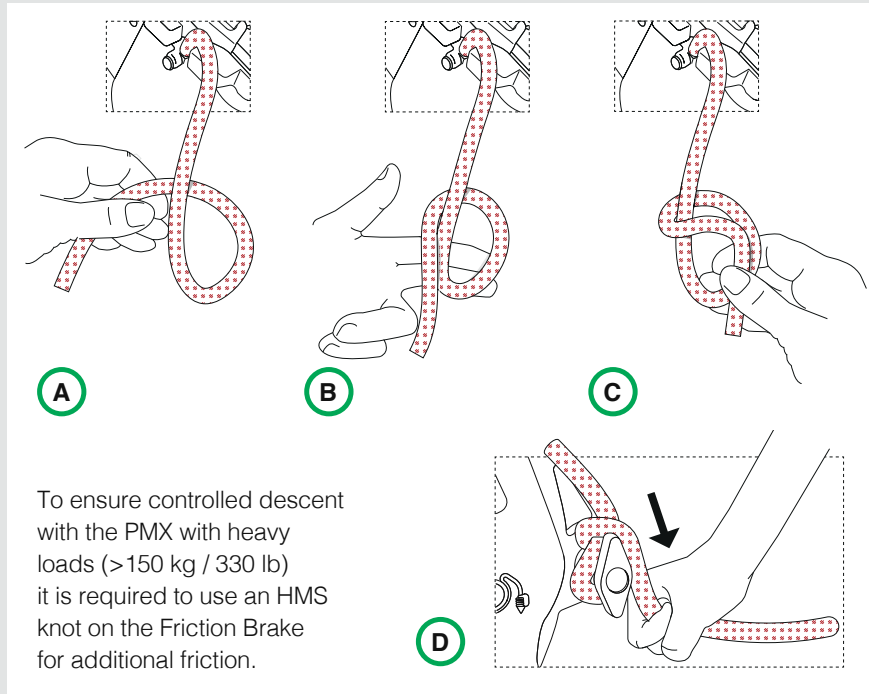

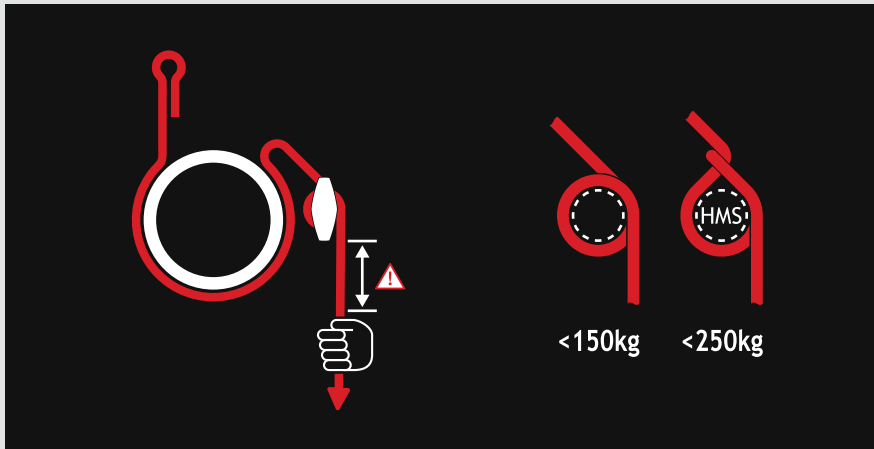

**Always use the Friction Brake when descending with the Ascender:**

**Load < 150 kg (330 lb):** Simply wind the rope around the bolt 1 or 2 times depending on friction required

**Load > 150-250 kg (330-551 lb):**  
An HMS knot must be used for optimum braking and control whilst descending

**! CAUTION**

Always descend in a controlled manner by using the Friction Brake for additional friction on the outgoing rope and holding it firmly with your right hand.

Keep your hands away from the Friction Brake. Ensure that hair, clothing or any loose items are not allowed to become caught.

## F.06 TWISTED ROPE AND ROTATION

Ensure, especially when descending, that the rope runs untwisted into the Ascender. Twisted ropes caught into the Rope Guide can cause a rope jam and can, in rare cases, result in rope damage.

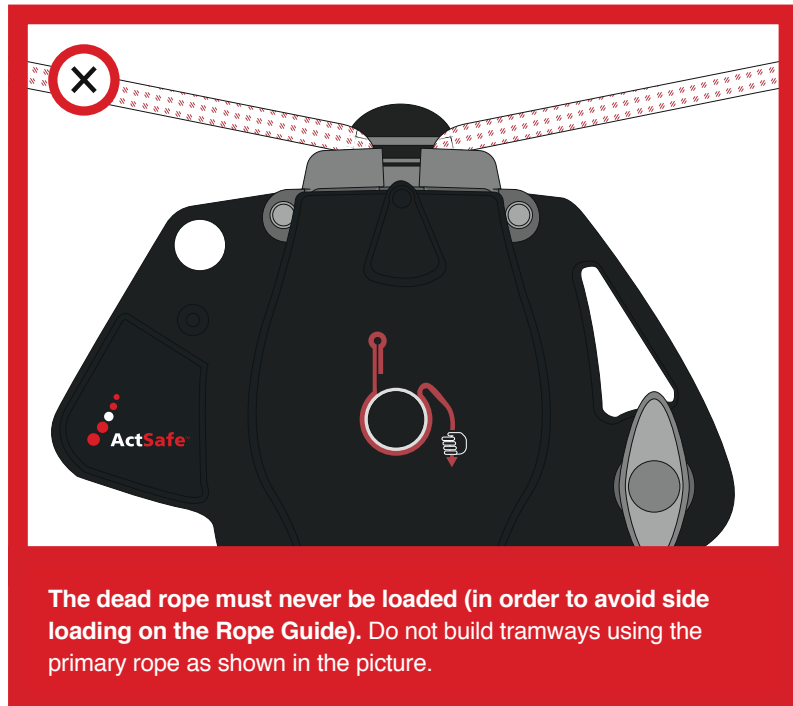



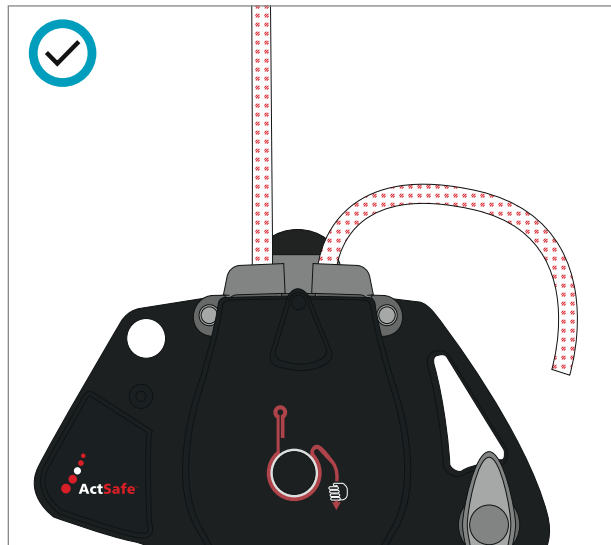

Ensure, especially when descending, that the rope runs untwisted into the Ascender. Twisted ropes caught into the Rope Guide can cause a rope jam and can, in rare cases, result in rope damage.

### **CAUTION**

When descending, make sure the rope is fed neatly into the Rope Grab so that there are no kinks or twists in the rope. Take special care when using long ropes to prevent twists or kinks. Good rope management is ESSENTIAL.

### **RECOMMENDATION**

When descending, hold the rope entering the Ascender to prevent it from running twisted into the Ascender.

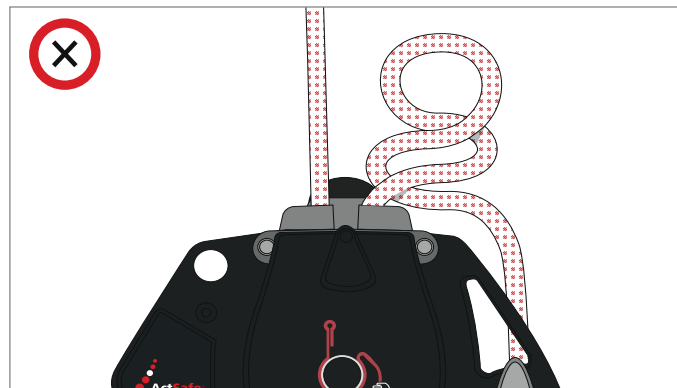

Stop immediately when a rope twist is observed, untwist and organise the rope before continuing.

## F.07 CHECKLIST BEFORE USE

Always check the Ascender before every use. Check the Ascender thoroughly and in accordance with your training and this manual.

If you are in any doubt about the condition of the Ascender, do not use it and contact your ActSafe supplier or ActSafe directly.

### ✓ **Engine Inspection**

Check following points on the Honda Engine:

- » Sufficient Fuel level
- » Correct Oil Level
- » Clean Air Filter
- » Starting engine
- » Throttle
- » Turning of the Engine with Engine Switch

### ✓ **Brake Testing**

Check following points on the Honda Engine:

- 1.** Attach the Ascender to a rigged rope, in a non-exposed location
- 2.** Connect backup system and Ascender to harness and ascend 50 cm off the ground and stop the Engine
- 3.** The Ascender should stay in the same position without slowly descending by itself
- 4.** Descend slowly, just before touching the ground release the Braking Lever

The Ascender should stop immediately. If the brake is slipping do not use the Ascender and get in touch with your ActSafe distributor.



✓ **Visual inspection of load-bearing parts**

» **Rope Guide (A)**

Check Rope Guide for obvious damage, deformation or sharp edges. Rope Guide should not be bent and must fit neatly with the Rope Cover. Check wear indicator, this should be completely intact

» **Rope Cover**

Check the Rope Cover function by opening and closing it. During closing the Rope Cover must lock unhindered into its position. Check the Rope Cover further for deformation, excessive wear or any sharp edges

» **Rope Wedge (B)**

Check Rope Wedge for deformation or any visible damage. The Rope Wedge should be straight, sit just above the bottom of the Rope Grab and should not touch the ribs on the inside of the Rope Grab

» **Rope Grab (C)**

Check that Rope Grab is clean and not filled with dirt, sand, paint or any other foreign material. Check the inside for obvious damage, signs of wear or sharp edges

» **Connection Sling and Karabiner (D)**

Check Connection Sling for wear, discoloration or damage such as cuts, abrasion and contaminants (paint, glues, chemicals). Take particular note of the condition of the Titanium Sling Bolt and Karabiner Loop. Inspect the Karabiner for wear, damage and deformation. Check that the Karabiner opens and locks correctly

## F.08 TRANSPORTATION

Carry the Ascender for short walking distances by the Lifting Handle with the Engine off and the Silencer away from your body.

When carrying the Ascender any further stow it in the transportation box as this will protect the Ascender from any damage. Before normal transport in the box, which gives the Ascender optimum protection, switch off and allow the winch to cool at least for 15 minutes.

For longer transportations make sure that the fuel tank is empty.

Always make sure the Ascender is secure before being transported in a vehicle.

## F.09 STORAGE

Depending on the region where you operate your winch, fuel formulations may deteriorate and oxidize rapidly. Fuel deterioration and oxidation can occur in as little as 30 days and may cause damage to the carburetor and/or fuel system. In case of prolonged storage ActSafe recommends to remove the fuel from the Fuel Tank and Karburetor.

If the Ascender is to be stored with petrol in the Fuel Tank and Carburetor, it is important to reduce the hazard of gasoline vapourignition. Select a well ventilated area.

Always clean and dry the Ascender and the transportation box before putting it away for storage.

Store the Ascender in a cool and dry place. It can be stored in the transportation box, make sure it is dry.

# G

## SERVICE & MAINTENANCE

Maintenance & cleaning  
of the Ascender

**G.01**

Engine maintenance

**G.02**

Trouble-shooting guide

**G.03**

# G

**Only use original spare parts and materials recommended and supplied by ActSafe Systems.**

## **Basic Inspection Guidance for users and third party inspection:**

To be used safely, each Ascender should meet following requirements at all times:

- » No obvious damage or excessive wear on Ascender and its components, as described in F.08 Checklist.
- » Basic function test of Ascender including Engine start, ascending, descending, Engine stop.
- » 1,25 x SWL dynamic load test; descending full speed and then stop with max 10 cm (3,9") slippage.
- » 1,5 x SWL static load test; no slippage allowed.



## **RECOMMENDATION**

Go through 'Checklist before use' (F.07) during every maintenance.

## G.01 MAINTENANCE & CLEANING OF THE ASCENDER

Repairs, annual service and inspection shall be carried out by an ActSafe-authorized service partner. More frequent inspection intervals may be required because of local regulations.

### Cleaning the Ascender

- ✓ Clean and dry the Ascender with a wet cloth or brush after use, removing all moisture and dirt.
- ✓ Dry dust can be removed with compressed air.
- ✓ Clean the Karabiner thoroughly, lubricate with thin oil and wipe dry.
- ✓ Check the engine oil, replace if needed. Check the air filter, clean or replace if needed.

### RECOMMENDATION

Remove the ignition cable before service. Do this to avoid accidental start-up during maintenance work.

Keep the engine cylinder fins and control parts free from dirt and other foreign substances, which could affect the revolution speed.

### Note

**DO NOT** use running water or any degreasing agent, never use a high-pressure washer!

**DO NOT** use a high-pressure cleaner.

## G.02 ENGINE MAINTENANCE

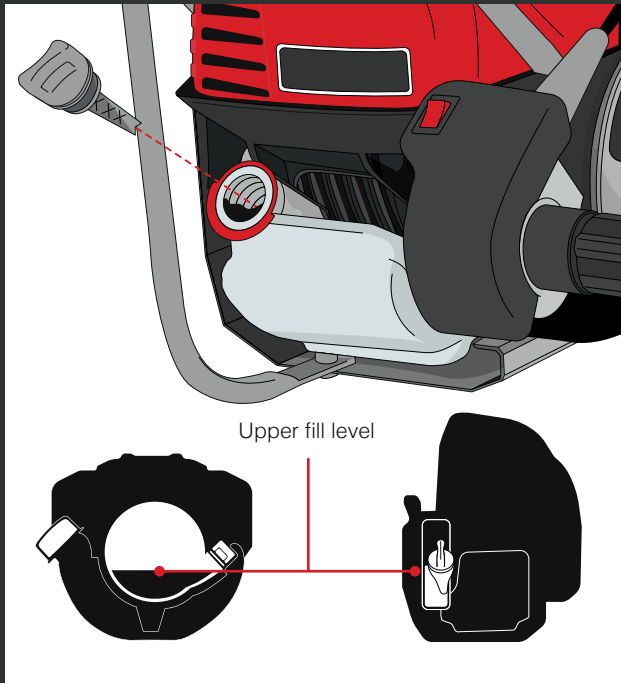

### Oil level check and change

Check the engine oil level before each use, or every 10 hours if operated continuously. Check the engine oil level with engine stopped and in a level position.

- » Remove the oil filler cap/dipstick and wipe it clean.
- » Insert and remove the oil filler/dipstick without screwing it into the oil filler neck, then remove it to check the oil level shown on the dipstick.
- » If the oil level is near or below the lower limit mark on the dipstick, fill to the bottom edge of the oil fill hole with SEA 10w-30 oil. To avoid overfilling or underfilling, be sure the engine is in a level position, as shown, while adding oil.
- » Reinstall the oil filler cap/dipstick and tighten securely.



### RECOMMENDATION

Drain the used oil when the engine is warm. Warm oil drains quickly and completely.



**For full information about the engine maintenance points and schedule, check the included owner's engine manual.**

**Be aware:** First oil change is required after first 10 hours of running the engine!  
(Normal service period 50 hours/6 months)

**FUEL FILLER CAP**

**OIL FILLER NECK**

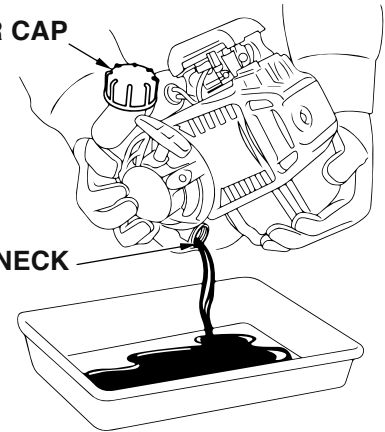

**NOTE**

Change the oil regularly to prolong the lifetime of the engine. Running the engine with a low oil level can cause engine damage.

## Carburetor

The Carburetor has a fixed setting for running at sea level. Special carburetor jets can be installed in the carburetor when operating the Ascender at higher altitudes ( > 2500 m / 8202 ft).

## Air Filter

The air filter should be cleaned daily or more often if working in exceptionally dirty areas in order to avoid problems such as:

- » Carburetor malfunctions
- » Starting problems
- » Engine power reduction
- » Unnecessary wear on the engine parts
- » Abnormal fuel consumption

## Spark plug

The spark plug can have deposits on the electrodes, which may result in malfunction and/or starting difficulties. The spark plug condition is influenced by:

- » A dirty air filter
- » Hard-running conditions

In some areas, local legislation requires using a resistor spark plug to suppress ignition signals. If the engine was originally equipped with a resistor spark plug, you have to choose the same type of spark plug whenever you replace it.



## Fuel

EU 95/US 91 Octane fuel is recommended for use in the engine. Aspen fuel may also be used. Do not mix these types of fuel since it can cause a clogged fuel filter.

## G.03 TROUBLESHOOTING GUIDE

If you need further assistance or are in any doubt please contact ActSafe Systems or your approved ActSafe distributor.

PROBLEM	PROBABLE CAUSE	REMEDY
<b>The engine does not start</b>	Empty tank	Refuel the Ascender
	Ignition cable loose	Reattach the ignition cable to the spark plug
	Wrong fuel	Empty the tank, clean and refuel the Ascender
	Too cold	Use choke
	Flooded engine	Turn down choke and wait 10 minutes and try again
	Dirty Spark plug	Clean spark plug

PROBLEM	PROBABLE CAUSE	REMEDY
<b>The engine dies</b>	Vacuum in fuel tank	Open valve in fuel lid (Contact ActSafe) or replace fuel cap
<b>The grab on the rope is poor, the rope slips</b>	Rope connected incorrectly	Reconnect the rope
	The rope is not suitable for the Ascender	Change the rope
	The Rope Grab is worn	The Ascender is in need of repair and service, contact ActSafe or an approved distributor
<b>The Rope Cover does not close</b>	Rope not loaded correctly	Open Rope Cover and check if rope is fitted correctly
	Dirt in Rope Cover	Clean Rope Cover and locking mechanism
	Damaged Rope Cover	The Ascender is in need of repair and service, contact ActSafe or an approved distributor

**PROBLEM**

## PROBABLE CAUSE

## REMEDY

<b>Descending too fast</b>	Heavy load (>150 kg)	Put the braking rope with an HMS knot around the friction brake
	New Rope	Put the braking rope a second time around the friction brake, or use HMS knot
<b>The lifting capacity is notably weak</b>	The fuel is wrong	Change to recommended fuel
	The winch is being used at high altitude	High altitude will result in loss of performance. The engine can be equipped for use at high altitude. Contact ActSafe or an approved distributor
	The engine is in bad condition	Service the engine





**POWER ASCENDERS  
WARRANTY TERMS**

Warranty terms

---

**H.01**

## H.01 WARRANTY TERMS

ActSafe Systems AB ("ActSafe") guarantees that the PMX Power Ascender ("Product") purchased has no defects in material and workmanship. This is subject to the terms of the limited warranty ("Warranty") given below.

Any claim must be made within the warranty period which is one year from delivery unless otherwise agreed.

ActSafe will, through repair or replacement as appropriate in ActSafe's reasonable discretion, remedy any defect that is covered by the limited warranty and notified in writing within the warranty period.

ActSafe reserves the right to use reconditioned parts with performance parameters equal to those of new parts in any repair performed under the Warranty.

### **Claim under ActSafe's warranty**

Claims under ActSafe's Warranty may be made only by direct customers of ActSafe who, upon ActSafe's request, can present the original sales invoice from ActSafe.

The Warranty is not transferable from one user or customer to another.

If you have purchased your product from an authorized distributor of ActSafe products, please contact the distributor for warranty claims.



## **Warranty Limitations**

The warranty does not extend to:

- (i) Products which have been modified, repaired or reconditioned by a party not authorised by the Seller;
- (ii) defects or damage resulting from failure to maintain or operate the Products in accordance with the Seller's recommendations;
- (iii) normal wear and tear;
- (iv) damages which are the result of abuse or negligence including but not limited to water intrusion, physical damage; electrical faults external to the Products, rust or corrosion;

(v) Products for which the serial number has been removed or tampered with; and (vi) Products to which a component or product not authorised by the Seller has been added. Repair and replacement in accordance with the warranty terms are the sole and exclusive remedies for defects. The Warranty is exclusive and no other warranties, whether statutory or implied shall apply to the Products, including but not limited to warranties of merchantability or fitness for a particular purpose. Any implied warranty that may be imposed by applicable law is limited to the warranty period.

Except as otherwise required by governing law, under no circumstances (including negligence) shall ActSafe, its affiliates, and their respective directors, officers, employees or agents be liable for any consequential, incidental, indirect, punitive, special or other similar damages, whether in action of contract, negligence or other tortious action, arising out of, in connection with or resulting from the sale or provision of any Products.





## TECHNICAL DATA

Ascender	<b>I.01</b>
Engine	<b>I.02</b>

## I.01 ASCENDER

PERFORMANCE/PART	VALUE	COMMENT
<b>Rope</b>	Personnel Lifting - EN 1891 A 11 mm (7/16"), Equipment Lifting -- ActSafe ELR	See our website for tested ropes. Polyamid ropes should be soaked before first use. See section C.01
<b>Safe Working Load (SWL)</b>	250 kg (551 lb) or max 2 persons	
<b>Ascent speed</b>	17 m/min at 100 kg / 220 lb) load (55 ft/min at 220 lb)	
<b>Descending speed</b>	User regulated	Recommended maximum descending speed 0,5 m/sec (1.64 ft/s)
<b>Recommended temperature range</b>	-20°C (4°F) to 40°C (104°F)	The Ascender can be used at other temperatures as well
<b>Weight</b>	13 kg (29 lb)	Excluding fuel
<b>Dimensions</b>	29x28x49 cm (11.4x11x19.3")	
<b>Transportation box dimensions</b>	33x34x53 cm (12.9x13.4x20.9")	
<b>Transportation box weight</b>	20 kg (44 lb)	
<b>Range</b>	750 metre at 100 kg load, with 1 fuel tank of 650cc (2460 ft at 220 lb with 1 tank of 0.67 U.S. qt) )	
<b>Max. continuous descending distance</b>	150 m (492 ft)	
<b>Noise level</b>	89 dB	
<b>Max windspeed</b>	12 m/s	Weather conditions should be stable and favourable to not affect the safety of personnel and/or lifting operation

## I.02 ENGINE

PERFORMANCE/PART	VALUE	COMMENT
Engine	Honda GX35	35.8 cc, Forced air-cooled 4-stroke OCH, single cylinder
Reduction rate	131,5:1	
Type		
Spark	CMR5H (NGK)	
Fuel	Unleaded EU 95/ US 91 Octane or higher.	
Fuel tank	0.65 L (0.17 gallon)	
Engine oil	SAE 10W-30	

**ActSafe Systems AB**

Sagbäcksvägen 13  
SE-43731 Lindome, Sweden

**T:** +46 31 65 56 60

**E:** [info@actsafe.se](mailto:info@actsafe.se)

**W:** [www.actsafe.se](http://www.actsafe.se)

© 2017 ActSafe Systems AB

